

QUICK SET UP MANUAL - WS-1912 WEATHER CENTER

Using 915MHz wireless transmission of weather data, this unique weather station can be powered using batteries for all your weather needs in the home or office.

This product offers:



INSTANT TRANSMISSION is the state-of-the-art new wireless transmission technology, exclusively designed and developed by LA CROSSE TECHNOLOGY. **INSTANT TRANSMISSION** offers you an immediate update (every 4.5 seconds!) (every 6.25 seconds for rain! optional) of all your outdoor data measured from the transmitters: follow your climatic variations in real-time!

Carefully open and check that the following contents are complete:

Item:	Consisting of:	Fittings:	Illustration:
Base Station	1) Main unit		
Thermo-Hygro Sensor (TX31U-IT)	1) Main unit 2) Rain protection cover	1) Wall mounting screws 2) Plastic anchors for screws 3) 2 x cable ties	

Wind Sensor (TX55U-IT)	1) Main unit with wind vane 2) 32ft cable (already attached the main unit) 3) Mast holder	1) 1 x U-bolts for mast holder 2) 2 x Washers 3) 2 x Nuts 4) 2 x cable ties	
-------------------------------	---	--	--

SETTING UP:

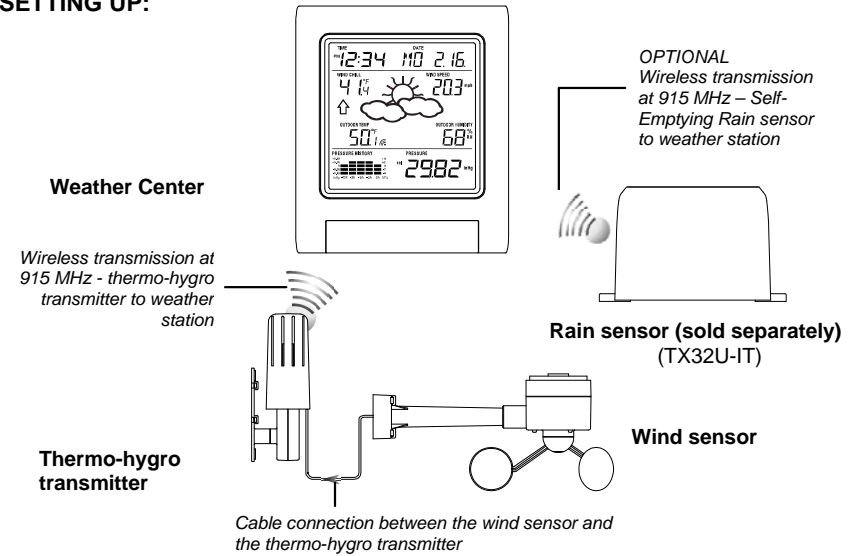

Note:

When putting the Weather Station into operation, it is important to have them in close proximity (e.g. on a table 5 ft from display) while completing wiring and set-up of the system. This step is important to allow testing of all components for correct function before placing and mounting them at their final destinations (See **Positioning** below). Allow all sensors to sit with the display for 15 minutes before mounting.

1. First, unwind the cables of the Wind sensor. Connect the Wind sensor to the Thermo-hygro transmitter by plugging the connector head into the socket of the Thermo-hygro sensor.
2. Next insert the batteries into the Thermo-hygro sensor and optional rain sensor (purchased separately) (See "**How to install and replace the batteries into the Thermo-hygro sensor**" and "**How to install and replace the batteries into the rain sensor**" (optional) below).
3. Then insert the batteries into the Weather Center (See "**How to install and replace the batteries into the Weather Center**" below). Once the batteries are installed, all segments of the LCD will light up. It will then display the time as 12:00, the date as 1.1.09, the weather icons, and air pressure value. "- - -" will be shown for outdoor data.
4. The Weather Center will start receiving data from the transmitter. The transmission reception icon will be blinking to indicate that the station is trying to get the thermo-hygro transmitter data. The outdoor temperature, humidity and wind data should then be displayed on the Weather Center. If this does not happen after 135 seconds, the batteries will need to be removed from all units. You will have to start again from step 2.
5. The transmitter reception icon is now blinking again to indicate that the station is trying to get the rain sensor data. It will stop blinking once the rain sensor has been detected. If this does not happen after 135 seconds, you will need to start again from step 2.

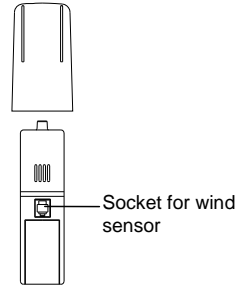

6. You may need to check the cable for correct connection and all the components for correct function by manually turning the wind-gauge (cups); tilting the rain sensor to hear the impact of the internal moving seesaw, etc. (see **Positioning** below).
7. Time and date must be manually set (See **Manual Setting** below).
8. After the Weather Center has been checked for correct function with regard to the above points and found fit, the initial set up of the weather station system is finished and the mounting of the system components can take place. It must be ensured however that all components work properly together at their chosen mounting or standing locations.

For example, if there appears to be problems with the 915 MHz radio transmission, they can mostly be overcome by slightly changing the mounting locations or turning the base station.

Note:

The radio communication between the receiver and the transmitters in the open field reaches distances of up to 330 feet, provided there are no interfering obstacles such as buildings, trees, vehicles, high voltage lines, etc.

9. Radio interferences created by cordless phones, PC screens, radios or TV sets can in some cases entirely cut off radio communication. Please consider this when choosing standing or mounting locations.

Note:

After batteries are installed in the transmitter, install the batteries in the weather center to receive the signal from the transmitters as soon as possible. If the weather center is powered more than 5 hours after the transmitter is powered, the weather center will never receive the signal successfully from the transmitters. In this case, you will need to reinstall the batteries for all the transmitters to redo the setup procedure.

After the batteries are installed, there will be synchronization between weather center and the transmitters. At this time, the signal reception icon will be blinking. When the signal is successfully received by the Weather Center, the icon will be switched on. (If it is not successful, the icon will not be shown in LCD) This allows you to see whether the last reception was successful (icon on) or not (icon off).

Short blinking of the icon shows that a reception is in progress.

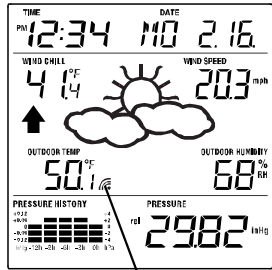

Transmitter signal reception icon

If the signal reception is not successful on the first frequency (915MHz) for 45 seconds, the frequency is changed to 920MHz and the learning is tried another 45 seconds. If still not successful, the reception is tried for 45 seconds on 910MHz. This will also be done for re-synchronization.

HOW TO INSTALL AND REPLACE THE BATTERIES INTO THE THERMO-HYGRO TRANSMITTER

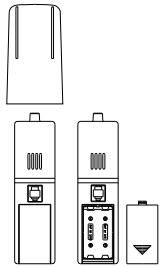

The outdoor Thermo-hygro transmitter works with 2 x AA IEC LR6, 1.5V batteries. To install and replace the batteries, please follow the steps below:

1. Uninstall the air flow cover of the transmitter.
2. Remove the battery compartment cover.
3. Insert the batteries, observing the correct polarity (see the marking in the battery compartment).
4. Replace the battery cover and the air flow cover onto the unit.

Note:

When changing batteries in any of the units, all units need to be reset by following the setup procedures. This is because a random security code is assigned by the thermo-hygro sensor at start-up

and this code must be received and stored by the weather center in the first several minutes of power being supplied to it.

HOW TO INSTALL AND REPLACE THE BATTERIES IN THE WEATHER STATION



The Weather Station works with 3 x AA, IEC LR6 1.5V batteries. When the batteries need to be replaced, the low battery symbol will appear on the LCD. To install or replace the batteries, please follow the steps below:

1. Remove the battery compartment cover.
2. Insert the batteries observing the correct polarity (see the marking in the battery compartment).
3. Replace the battery cover.

HOW TO INSTALL AND REPLACE BATTERIES INTO THE RAIN SENSOR (OPTIONAL; SOLD SEPERATELY)

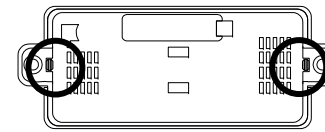

Figure 1

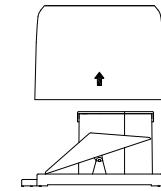

Figure 2

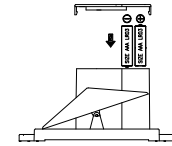

Figure 3

1. Unlock the main cover from the rain sensor base and remove the cover.
2. Remove the battery cover at the top of the rain sensor.
3. Insert 2 x AAA, IEC LR3, 1.5V batteries into the battery compartment, observing the correct polarity.
4. Replace the battery cover and the main cover on the unit.

Note:

In the event of changing batteries in any of the units, all units need to be reset by following the setting up procedures. This is because a random security code is assigned by the transmitter and rain sensor (optional) at start-up and this code must be received and stored by the Weather Station in the first 90 seconds of power being supplied to it.

BATTERY CHANGE:

It is recommended to replace the batteries in all units regularly to ensure optimum accuracy of these units. (Battery life –see **Specifications**)



Please participate in the preservation of the environment. Return used batteries to an authorised depot.

Note:

The stored History record will not be kept after the battery change is done on the weather station.

FUNCTION KEYS:

Weather Station:

The Weather Station has 4 easy-to-use function keys.

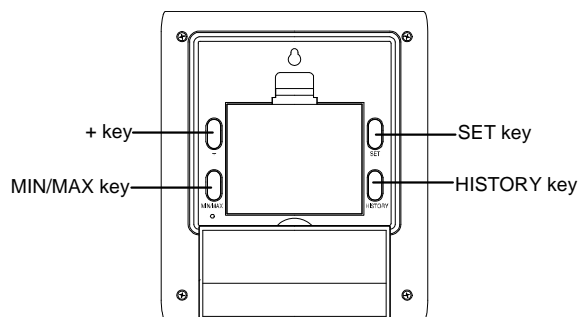

SET key

- Press and hold to enter manual setting modes: LCD contrast, Manual time setting, 12/24 hour time display, Calendar setting, °C/ °F temperature unit, Wind speed unit, Rainfall unit, Pressure unit, Relative pressure reference setting, Weather tendency threshold setting
- Press to toggle between the display of Mode 1 or Mode 2:
Mode1: "Wind speed + outdoor temp + rel. pressure"
Mode 2: "Gust + Dew Point temp + rainfall data (only if there is a rain sensor- optional)"
(Mode 2 displayed will be shown for 30 seconds. Then it will return to normal display)
- Press to activate the reset mode when MAX or MIN record is shown

+ key

- In display Mode 1, press to toggle between the display of date, weekday + date, Indoor temp, or second
- In display Mode 2, press to toggle between the display of Relative Pressure, 24 hour rainfall and Total rainfall (only if there is a rain sensor- optional).
- Press to adjust (increase) the level of different settings
- Press to confirm to reset the MIN/MAX record

HISTORY key

- Press to display the weather data history records
- Press to exit manual setting mode

MIN/MAX key

- Press to display MIN/MAX records of various weather data
- Press to adjust (decrease) the level of different settings

LCD SCREEN

The LCD screen is split into 3 sections displaying the following information:

1. Time and date/ indoor temp/ second
2. Wind data, outdoor temperature and humidity, dew point, weather forecast icon and tendency indicator
3. Air pressure history, relative air pressure, rainfall data (optional)

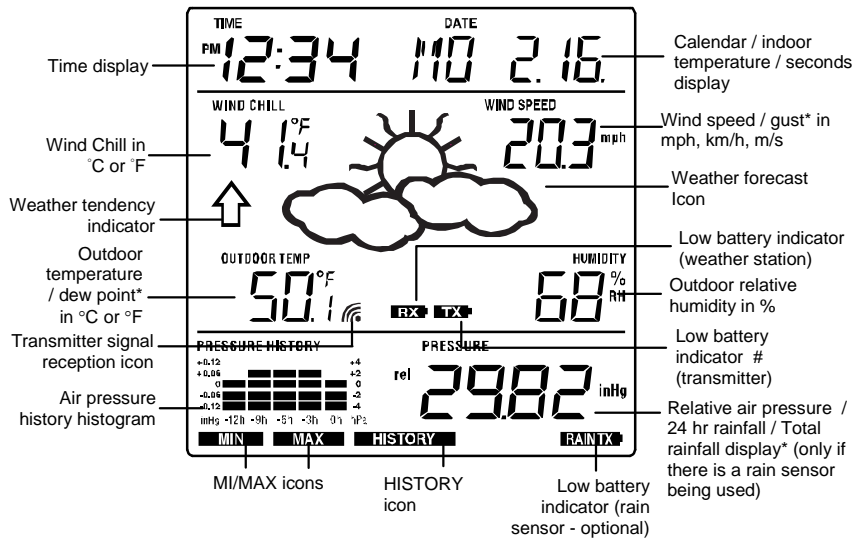

When the signal from the transmitter/ or Rain sensor (optional) is successfully received by the Weather Station, the icon will be switched on. (If not successful, the icon will not be shown on the LCD). User can therefore easily see whether the last reception was successful ("ON" icon) or not ("OFF" icon). On the other hand, the short blinking of the icon shows that a reception is being done at that time.

* In normal display user may press the SET key shortly to toggle between Mode1 and Mode 2 display:

Mode 1: Wind speed, outdoor temperature, relative air pressure are shown.

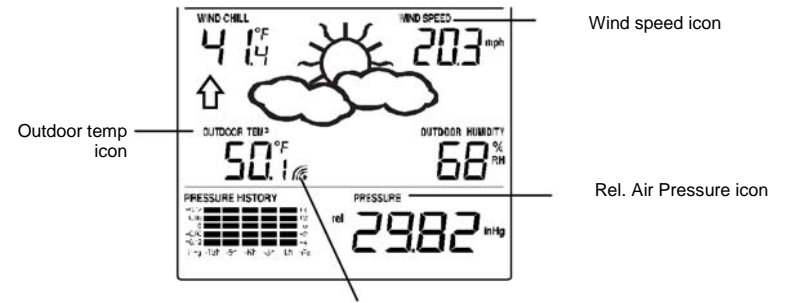

In Mode 1, this reception icon is showing the condition of the reception of the signal from Thermo-hygro transmitter

Mode 2: Wind gust, dew point, and rainfall (optional) reading are shown.

Note: To view the rainfall data, press the + key after entering Mode 2 display.

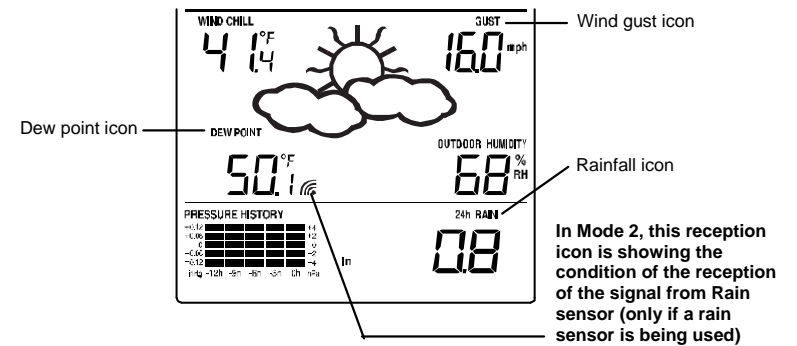

MANUAL SETTINGS:

The following manual settings can be changed once the SET key is pressed and held for about 3 seconds:

- LCD contrast setting
- Manual time setting
- 12/24 hour time display
- Calendar setting
- °C/ °F temperature unit setting
- Wind speed unit
- Rainfall unit setting
- Air pressure unit setting
- Relative pressure reference value setting
- Weather tendency threshold value
- Storm warning threshold value
- Alarm On/ Off setting

LCD CONTRAST SETTING

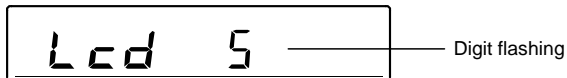

The LCD contrast has 8 levels, from "LCD 1" to "LCD8" (default setting is LCD 5):

1. Press the SET key, the contrast level digit will start flashing.
2. Use the + or MIN/MAX key to adjust the level of contrast.
3. Confirm with the SET key and enter the **MANUAL TIME SETTING**.

MANUAL TIME SETTING:

You then may manually set the time of the clock by following the steps below:

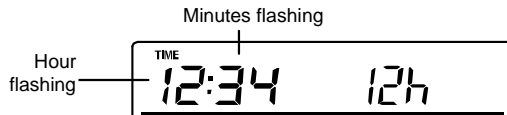

1. The hour digit will start flashing.
2. Use the + or MIN/MAX key to set the hour.
3. Press the SET key to switch to the minutes. The minute digit will start flashing.
4. Use the + or MIN/MAX key to set the minutes (holding of the key will forward the digit by 5)
5. Confirm the time with the SET key and enter the **12/24 HOUR TIME DISPLAY SETTING**.

12/24 HOUR TIME DISPLAY SETTING:

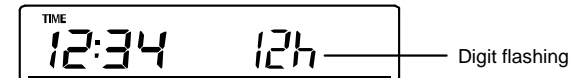

The time can be set to view as 12 hour or 24 hour format. The default time display mode is "12h". To set to "24h" time display:

1. Use the + or MIN/MAX key to toggle the value.
2. Confirm with the SET key and enter the **CALENDAR SETTING**.

CALENDAR SETTING:

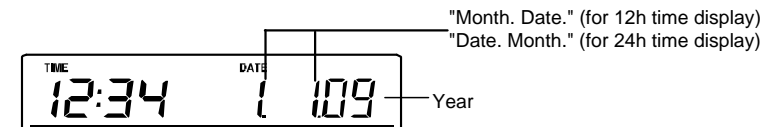

The date default of the Weather Station is 1. 1. of year 2009. The date can be set manually by proceeding as follows.

1. The year digit starts flashing.
2. Use the + or MIN/MAX key to set the year (pressing and holding the key will forward the digit by 5). The range runs from "00" (2000) to "99" (2099).
3. Press the SET key to confirm the year and enter the month setting. The month digit will start flashing.
4. Use the + or MIN/MAX key to set the month.
5. Press the SET key to confirm the month and enter the date setting mode. The date digit will start flashing.

- Use the + or MIN/MAX key to set the date.
- Confirm all calendar settings with the SET key and enter the **°C/°F TEMPERATURE UNIT SETTING**.

°C/°F TEMPERATURE UNIT SETTING

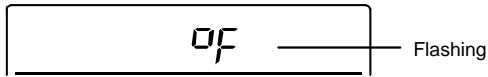

The temperature display can be selected to show temperature data in °F or °C. (default °F)

- The temperature unit is flashing
- Use the + or MIN/MAX key to toggle between “°F” or “°C”.
- Confirm with the SET key and enter the **WIND SPEED UNIT SETTING**

WIND SPEED UNIT SETTING



The wind speed unit can be set as mph (mile per hour), km/h (kilometre per hour), or m/s (meter per second). The default unit is mph.

- Use the + or MIN/MAX key to toggle between the unit “mph”, “km/h”, or “m/s”
- Confirm with the SET key and enter the **RAINFALL UNIT SETTING**.

RAINFALL UNIT SETTING (OPTIONAL)

Note: the rain unit setting is only available if there is a rain sensor. Skip this setting by pressing the SET key again to enter the Relative Air Pressure Unit Setting.

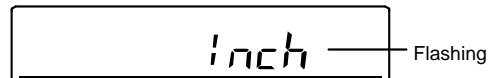

The total rainfall unit can be set as inch or mm. The default unit is inch.

- Use the + or MIN/MAX key to toggle between the unit “mm” or “Inch”

- Confirm the unit with the SET key and enter the **RELATIVE AIR PRESSURE UNIT SETTING**.

RELATIVE AIR PRESSURE UNIT SETTING



The relative air pressure can be set as hPa or inHg. The default unit is inHg.

- Use the + or MIN/MAX key to toggle between the unit “hPa” or “inHg”
- Confirm the unit with the SET key and enter the **RELATIVE PRESSURE REFERENCE VALUE SETTING**

RELATIVE PRESSURE REFERENCE VALUE SETTING

Note:

The default reference pressure value of the barometer is 29.91inHg (1013 hPa) when batteries are first inserted. **For an exact measurement, it is necessary to first adjust the barometer to your local relative air pressure (related to elevation above sea level)**. Ask for the current atmospheric pressure of your home area (Local weather service, www, calibrated instruments in public buildings, airport).

The relative air pressure can be manually set to another value within the range of 27.14 to 31.90 inHg (919 to 1080 hPa) for a better reference.



- The current relative pressure value will start flashing
- Use the + or MIN/MAX key to increase or decrease the value. Keep holding the key will allow the value to increase faster.
- Confirm with the SET key and enter the **WEATHER TENDENCY THRESHOLD VALUE SETTING**

Note:

This calibration facility is useful for those users living at various elevations above sea level, but wanting their air pressure display to be based on sea level elevation.

WEATHER TENDENCY THRESHOLD VALUE SETTING

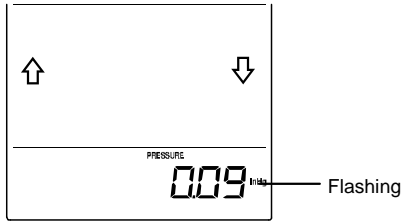

You may select a definite switching sensitivity value, .06, .09, or .12 inHg (2-4 hPa) for the change in the display of weather icons. This represents the "sensitivity" of the weather forecast (the smaller the value selected, the more sensitive the weather forecast). The default value is 0.09 inHg (3 hPa).

1. The threshold value will start flashing
2. Use the + or MIN/MAX key to select the value.
3. Confirm with the SET key and enter the **STORM WARNING THRESHOLD VALUE SETTING.**

STORM WARNING THRESHOLD VALUE SETTING

You may also define a switching sensitivity value for the Storm warning display at a decrease of air pressure from .09 inHg to .27 inHg (3 hPa a 9 hPa) over 6 hours (Default 0.15 inHg (5 hPa)).

The threshold value will start flashing.

1. Use the + or MIN/MAX key to select the value.
2. Confirm with the SET key and enter the **STORM ALARM ON/ OFF SETTING**

15

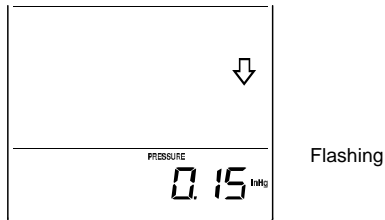

STORM ALARM ON/ OFF SETTING

Note: the storm alarm ON/OFF setting is not available on this model. Skip and exit this setting by pressing the SET key.

TO EXIT THE MANUAL SETTING MODE

To exit the manual setting anytime during the manual setting modes, press the HISTORY key anytime or wait for the automatic timeout. The mode will return to the normal time display.

Important Notes:

After you have followed the aforementioned set-up procedures, please read the main manual for the following important functions of the weather center in detail:

- Viewing wind / rainfall and air pressure data
- Viewing Max/ Max weather data
- Viewing History data record

Mounting the units:

Using 915MHz wireless transmission gives users little restriction on placement because all units can be positioned virtually anywhere within a 330 ft / 100 meters radius of the base station. Please ensure that the cable included in this set meets your distance requirements (see accessories in the main user manual for adding extension cables).

Important: Ensure all signals can be received and/or all cable distances meet with your requirements at the point of fixing particularly before you start drilling any mounting holes.

Wind sensor

Secure the main unit to the shaft of the mast holder using the single screw provided with the CUPS ON THE BOTTOM. Now fix the entire unit to a suitable mast using the U-bolt, washers and nuts found in this set.

Note: For best results mount the wind sensor onto a mast to allow the wind to freely travel from all directions to enable an accurate reading (ideal mast size should be from Ø 5/8" to 1 1/4"). Ensure that the cable of the wind sensor meets your distance requirements

Thermo-hygro Sensor

To wall mount the thermo-hygro sensor, fix the wall holder onto the desired wall (2 screws are supplied), plug the sensor firmly into the wall holder and then carefully replace the rain cover back over the thermo-hygro sensor.

16

Note: After mounting the units, should the weather data not be received, user may need to remove the batteries from all units and redo the set-up procedures after about 5 minutes.

Rain sensor (optional)

The rain sensor should be mounted horizontally about 2-3ft off from the ground (or higher) in an open area away from trees or other coverings to allow rain to fall naturally for an accurate reading.

Note: For best results ensure the base is horizontal to allow maximum drainage of any collected rain. Mount with 1 screw snug but not tight for most accurate readings.

WARRANTY INFORMATION

La Crosse Technology, Ltd provides a 1-year limited warranty on this product against manufacturing defects in materials and workmanship.

This limited warranty begins on the original date of purchase, is valid only on products purchased and used in North America and only to the original purchaser of this product. To receive warranty service, the purchaser must contact La Crosse Technology, Ltd for problem determination and service procedures. Warranty service can only be performed by a La Crosse Technology, Ltd authorized service center. The original dated bill of sale must be presented upon request as proof of purchase to La Crosse Technology, Ltd or La Crosse Technology, Ltd's authorized service center.

La Crosse Technology, Ltd will repair or replace this product, at our option and at no charge as stipulated herein, with new or reconditioned parts or products if found to be defective during the limited warranty period specified above. All replaced parts and products become the property of La Crosse Technology, Ltd and must be returned to La Crosse Technology, Ltd.

Replacement parts and products assume the remaining original warranty, or ninety (90) days, whichever is longer. La Crosse Technology, Ltd will pay all expenses for labor and materials for all repairs covered by this warranty. If necessary repairs are not covered by this warranty, or if a product is examined which is not in need or repair, you will be charged for the repairs or examination.

The owner must pay any shipping charges incurred in getting your La Crosse Technology, Ltd product to a La Crosse Technology, Ltd authorized service center. La Crosse Technology, Ltd will pay ground return shipping charges to the owner of the product to a USA address only.

Your La Crosse Technology, Ltd warranty covers all defects in material and workmanship with the following specified exceptions: (1) damage caused by accident, unreasonable use or neglect (including the lack of reasonable and necessary maintenance); (2) damage occurring during shipment (claims must be presented to the carrier); (3) damage to, or deterioration of, any accessory or decorative surface; (4) damage resulting from failure to follow instructions contained in your owner's manual; (5) damage resulting from the performance of repairs or alterations by someone other than an authorized La Crosse Technology, Ltd authorized service center; (6) units used for other than home use (7) applications and uses that this product was not intended or (8) the products inability to receive a signal due to any source of interference.

This warranty covers only actual defects within the product itself, and does not cover the cost of installation or removal from a fixed installation, normal set-up or adjustments, claims based on misrepresentation by the seller or performance variations resulting from installation-related circumstances.

LA CROSSE TECHNOLOGY, LTD WILL NOT ASSUME LIABILITY FOR INCIDENTAL, CONSEQUENTIAL, PUNITIVE, OR OTHER SIMILAR DAMAGES ASSOCIATED WITH THE OPERATION OR MALFUNCTION OF THIS PRODUCT. THIS PRODUCT IS NOT TO BE USED FOR MEDICAL PURPOSES OR FOR PUBLIC INFORMATION. THIS PRODUCT IS NOT A TOY. KEEP OUT OF CHILDREN'S REACH.

This warranty gives you specific legal rights. You may also have other rights specific to your State. Some States do not allow the exclusion of consequential or incidental damages therefore the above exclusion of limitation may not apply to you.

For warranty work, technical support, or information contact:

La Crosse Technology, Ltd
2817 Losey Blvd. S.
La Crosse, WI 54601
Phone: 608.782.1610
Fax: 608.796.1020

www.lacrossetechnology.com/support (warranty work)

For more information, please visit:
www.lacrossetechnology.com/1912

All rights reserved. This handbook must not be reproduced in any form, even in excerpts, or duplicated or processed using electronic, mechanical or chemical procedures without written permission of the publisher.

This handbook may contain mistakes and printing errors. The information in this handbook is regularly checked and corrections made in the next issue. We accept no liability for technical mistakes or printing errors, or their consequences.

All trademarks and patents are acknowledged.