

# WS-9151U

## Wireless 433 MHz Weather Station

### Instruction Manual

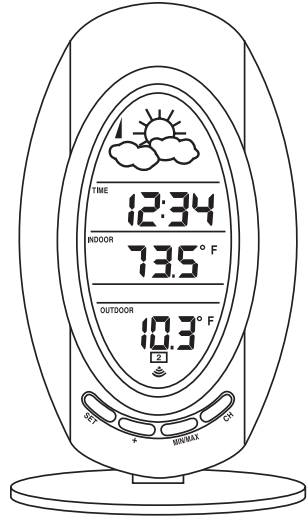

#### FCC DISCLAIMER

This device complies with part 15 of the FCC rules. Operation is subject to the following two conditions:

- (1) This device may not cause harmful interference.
- (2) This device must accept any interference received, including interference that may cause undesired operation.



weather.com

Electronic Weather Instruments  
by LA CROSSE  
TECHNOLOGY

## Contents

Language	Page
English	2
French	14
Spanish	27

## TABLE OF CONTENTS

Topic	Page
Quick Setup	3
Inventory of Contents	4
<b>Detailed Setup Guide</b>	
Battery Installation	5
Setting the Time	6
<b>Features</b>	
Minimum and Maximum Temperatures	6
Resetting Minimum and Maximum Temperatures	6
Adding additional remote temperature sensors (optional)	6
Weather Forecast	7
Weather Icons	7
Tendency Arrow	8
Mounting	9
Troubleshooting	9
Maintenance and Care	10
Specifications	11
Warranty Information	11

## QUICK SETUP

**Hint:** Use good quality Alkaline Batteries and avoid rechargeable batteries.

1. Have the indoor temperature station and remote temperature sensor 3 to 5 feet apart.
2. Batteries should be out of both units for 10 minutes.
3. Place the batteries into the **remote temperature sensor** first then into the indoor temperature station.  
(All remote temperature sensors must be started before the indoor temperature station)
4. **DO NOT PRESS ANY BUTTONS FOR 10 MINUTES.**

In this time the indoor temperature station and remote temperature sensor will start to talk to each other and the display will show both the indoor temperature and an outdoor temperature. If the indoor temperature station does not display both temperatures after the 10 minutes please retry the set up as stated above. After both indoor and outdoor temperatures are displayed for 10 minutes you can place your remote temperature sensor outdoors and set your time.

The remote temperature sensor should be placed in a dry, shaded area. The remote temperature sensor has a range of 80 feet. Any walls that the signal will have to pass through will reduce distance. An outdoor wall or window will have 20 to 30 feet of resistance and an interior wall will have 10 to 20 feet of resistance. Your distance plus resistance should not exceed 80 ft. in a straight line.

**NOTE:** Fog and mist will not harm your remote temperature sensor but direct rain must be avoided.

To complete the set up of your indoor temperature station after the 10 minutes have passed please follow the steps in the detailed set up guide on page 5-6.

## INVENTORY OF CONTENTS

1. The indoor weather station (Figure 1)
2. The remote temperature sensor (TX6U) and mounting bracket. (Figure 2)
3. 3 each, 1/2" Philips screws.
4. One strip of double sided adhesive tape.
5. Instruction Manual and Warranty Card.

Figure 1

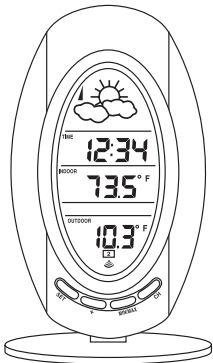
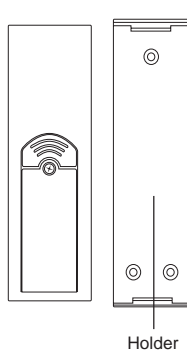

Figure 2



## ADDITIONAL EQUIPMENT (not included)

1. 1 Philips screwdriver.
2. 2 Fresh AA Alkaline batteries.
3. 2 Fresh AA Alkaline batteries.

## DETAILED SETUP GUIDE

### Battery Installation

1. Install 2 AA batteries in the remote temperature sensor. Make sure they do not spring free, or start-up problems may occur.

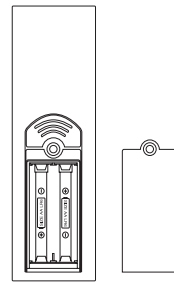

2. Install 2 AA batteries in the indoor weather station. **Do not press any buttons for at least ten minutes.**

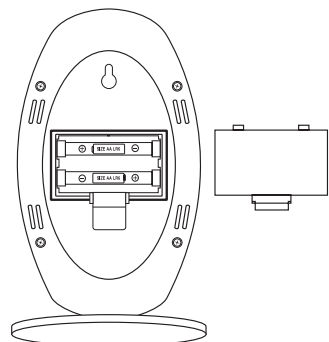

## Setting the time



1. Press and hold the "SET" key for 4 seconds.
2. The hour will flash.
3. Press and release the "+" key to advance the hour.
4. Press and release the "SET" key.
5. The minute is flashing.
6. Press and release the "+" key to advance the minutes.
7. Press and release the "SET" key to exit programming.

## FEATURES

### Minimum and Maximum Temperatures

1. Press and release the "MIN/MAX" button, "MAX" appears between the indoor and remote temperatures.
2. The recorded maximum indoor and remote temperature is displayed.
3. Press and release the "MIN/MAX" button.
4. "MIN" appears between the indoor and remote temperatures.
5. The recorded minimum temperature is displayed.
6. Press and release the "MIN/MAX" button to exit min/max mode.
7. To view optional additional sensors, press and release the "CH" button while viewing the minimum or maximum temperatures.

### Resetting Min and Max Temperatures

To reset both the minimum and maximum temperatures-press and hold the "MIN/MAX" button for 5 seconds.

### Adding Additional Remote Temperature Sensors (optional)

The WS-9151U is able to receive signals from 3 different remote temperature sensors. Following are some brief instructions for the basic set-up of remote temperature sensor units

with the WS-9151U. These extra remote temperature sensors can be purchased through the same dealer as this unit, or by contacting La Crosse Technology directly. A TX6U will monitor temperature only, a TX3U will monitor temperature and display the temperature on its LCD, and the TX3UP will monitor the temperature of water or soil via a probe.

When setting up multiple remote temperature sensors, it is important to remove the batteries from all existing units in operation, then to insert batteries first into all the remote temperature sensors. Second install batteries into the indoor weather station and do not press any buttons for ten minutes. Transmission problems will arise if this is not done correctly.

To view the temperature of a different remote temperature sensor unit, press and release the "CH" button. A shift from one number to the next should be observed in the OUTDOOR LCD.

### Weather Forecast

The weather forecasting feature is estimated to be 75% accurate. The weather forecast is based solely upon the change of air pressure over time. The WS-9151U averages past air-pressure readings to provide an accurate forecast, creating a necessity to disregard all weather forecasting for 12-24 hours after the unit has been set-up, reset, or moved from one altitude to another (i.e. from one floor of a building to another floor). In areas where the weather is not affected by the change of air pressure, this feature will be less accurate.

### Weather Icons

There are 3 possible weather icons that will be displayed in the FORECAST LCD:

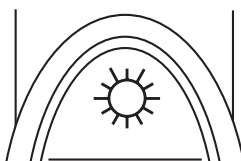

**Sunny**-indicates that the weather is expected to improve (not that the weather will be sunny).



**Sun with Clouds**-indicates that the weather is expected to be fair (not that the weather will be sunny with clouds).



**Clouds with Rain**-indicates that the weather is expected to get worse (not that the weather will be rainy).

The weather icons change when the unit detects a change in air pressure. The icons change in order, from "sunny" to "partly sunny" to "cloudy" or the reverse. It will not change from "sunny" directly to "rainy", although it is possible for the change to occur quickly. If the symbols do not change then the weather has not changed, or the change has been slow and gradual.

### Weather Tendency Arrows

Other possible displays in the FORECAST LCD are 2 weather tendency arrows, one that points up (on the left side of the LCD) and one that points down (on the right side of the LCD). These arrows reflect current changes in the air pressure. An arrow pointing up indicates that the air pressure is increasing and the weather is expected to improve or remain good. An arrow pointing down indicates that the air pressure is decreasing and the weather is expected to become worse or remain poor. No arrow means the pressure is stable.

## MOUNTING

**Note:** To achieve a true temperature reading, avoid mounting in direct sunlight. We recommend that you mount the remote temperature sensor on a North-facing wall. The sending range is 80ft; obstacles such as walls, concrete, and large metal objects will reduce the range. Place both units in their desired location before permanently mounting.

### Remote Temperature Sensor

Remove the mounting bracket from the remote temperature sensor. Mount the bracket in the desired location with either screws or adhesive tape. Insert remote temperature sensor into mounting bracket.

### Indoor Weather Station

The indoor weather station comes with the table stand already mounted. If you wish to use the table-stand all that is required is to place the indoor weather station in an appropriate location.

To wall mount the indoor weather station first remove the table stand. Next insert an appropriate screw in your desired location. Using the integrated hanging hole on the back of the unit, slip indoor weather station over the screw and pull down to secure.

## TROUBLESHOOTING

**NOTE:** For problems not solved, please contact La Crosse Technology via e-mail or phone, or visit our website, [www.lacrossetechnology.com](http://www.lacrossetechnology.com)

**Problem:** The LCD is faint  
**Solution:** Replace batteries

**Problem:** No outdoor temperature is displayed.  
**Solution:**

1. Remove all batteries, reinsert into remote temperature sensor first, then into the indoor weather station.
2. Place remote temperature sensor closer to the indoor weather station.
3. Be sure all batteries are fresh.

- Place remote temperature sensor and indoor weather station in position so the straight-line signal is not passing through more than two or three walls.

**Problem:**

Temperatures do not match if units are placed next to each other.

**Solution:**

Each temperature sensor is manufactured to be accurate to within 1 degree plus or minus and under normal conditions, so two sensors could be as much as 2 degrees different. However, the difference can be exaggerated further because the sensors are designed for different working environments. The indoor sensor is less responsive to ambient air currents because of the shielding effect of the display's case. In addition, the case can act as a heat sink to absorb and store heat from external sources (i.e. handling of the case or radiant heat). Also, the much greater range of the outdoor temperature sensor requires a different calibration curve than the indoor range. Error is usually greater at the extreme ends of a range, making it harder to compare different ranges with different curves. Under non-laboratory conditions, it is difficult to compensate for the above factors and obtain an accurate comparison.

**MAINTENANCE AND CARE INSTRUCTIONS**

- Extreme temperatures, vibration, and shock should be avoided to prevent damage to the units.
- Clean displays and units with a soft, damp cloth. Do not use solvents or scouring agents; they may mark the displays and casings.
- Do not submerge in water.
- Do not subject the units to unnecessary heat or cold by placing them in the oven or freezer.
- Opening the casings invalidates the warranty. Do not try to repair the unit. Contact La Crosse Technology repairs.

**SPECIFICATIONS**

Transmitting Frequency 433MHz

**Measuring Temperatures**

Indoor Weather Station 32°F to 156.2°F with 0.2°F resolution  
(0°C to 69.0°C with 0.1°C resolution)

Remote Temperature Sensor

-21.8°F to 156.2°F with 0.2°F resolution  
(-29.9°C to 69.0°C with 0.1°C resolution)

Temp accuracy

+/- 1°F (+/- .5°C)

Transmitting range

Maximum 80 feet (25m) open space

**Temperature check**

Indoor

Every 10 seconds

Outdoor

Twice in 10 minutes

**Batteries-(Alkaline recommended)**

Remote Temperature Sensor 2 x AA, 1.5V

Indoor Weather Station 2 x AA, 1.5V

Dimensions: (H x L x W)

Indoor Weather Station 6.3" x 3.26" x 1.21"  
(160 x 92 x 30.7 mm)

Remote Temperature Sensor 5.04" x 1.57" x 0.9"  
(128 x 40 x 23 mm)

Battery life

Approximately 1 year

**WARRANTY INFORMATION**

La Crosse Technology, Ltd provides a 1-year limited warranty on this product against manufacturing defects in materials and workmanship.

This limited warranty begins on the original date of purchase, is valid only on products purchased and used in North America and only to the original purchaser of this product. To receive warranty service, the purchaser must contact La Crosse Technology, Ltd for problem determination and service procedures. Warranty service can only be performed by a La Crosse Technology, Ltd authorized service center. The original dated bill of sale must be presented upon request as proof of purchase to La Crosse Technology, Ltd or La Crosse Technology, Ltd's authorized service center.

La Crosse Technology, Ltd will repair or replace this product, at our option and at no charge as stipulated herein, with new or reconditioned parts or products if found to be defective

## WARRANTY INFORMATION

La Crosse Technology, Ltd provides a 1-year limited warranty on this product against manufacturing defects in materials and workmanship.

This limited warranty begins on the original date of purchase, is valid only on products purchased and used in North America and only to the original purchaser of this product. To receive warranty service, the purchaser must contact La Crosse Technology, Ltd for problem determination and service procedures. Warranty service can only be performed by a La Crosse Technology, Ltd authorized service center. The original dated bill of sale must be presented upon request as proof of purchase to La Crosse Technology, Ltd or La Crosse Technology, Ltd's authorized service center.

La Crosse Technology, Ltd will repair or replace this product, at our option and at no charge as stipulated herein, with new or reconditioned parts or products if found to be defective during the limited warranty period specified above. All replaced parts and products become the property of La Crosse Technology, Ltd and must be returned to La Crosse Technology, Ltd. Replacement parts and products assume the remaining original warranty, or ninety (90) days, whichever is longer. La Crosse Technology, Ltd will pay all expenses for labor and materials for all repairs covered by this warranty. If necessary repairs are not covered by this warranty, or if a product is examined which is not in need of repair, you will be charged for the repairs or examination. The owner must pay any shipping charges incurred in getting your La Crosse Technology, Ltd product to a La Crosse Technology, Ltd authorized service center. La Crosse Technology, Ltd will pay ground return shipping charges to the owner of the product to a USA address only.

Your La Crosse Technology, Ltd warranty covers all defects in material and workmanship with the following specified exceptions: (1) damage caused by accident, unreasonable use or neglect (including the lack of reasonable and necessary maintenance); (2) damage occurring during shipment (claims must be presented to the carrier); (3) damage to, or deterioration of, any accessory or decorative surface; (4) damage resulting from failure to follow instructions contained in your owner's manual; (5) damage resulting from the performance of repairs or alterations by someone other than an authorized La Crosse Technology, Ltd authorized service center; (6) units used for other than home use (7) applications and uses that this product was not intended or (8) the products inability to receive a signal due to any source of interference.. This warranty covers only actual defects within the product itself, and does not cover the cost of installation or removal from a fixed installation, normal set-up or

adjustments, claims based on misrepresentation by the seller or performance variations resulting from installation-related circumstances.

LA CROSSE TECHNOLOGY, LTD WILL NOT ASSUME LIABILITY FOR INCIDENTAL, CONSEQUENTIAL, PUNITIVE, OR OTHER SIMILAR DAMAGES ASSOCIATED WITH THE OPERATION OR MALFUNCTION OF THIS PRODUCT. THIS PRODUCT IS NOT TO BE USED FOR MEDICAL PURPOSES OR FOR PUBLIC INFORMATION. THIS PRODUCT IS NOT A TOY. KEEP OUT OF CHILDREN'S REACH.

This warranty gives you specific legal rights. You may also have other rights specific to your State. Some States do not allow the exclusion of consequential or incidental damages therefore the above exclusion of limitation may not apply to you.

For warranty work, technical support, or information contact:

La Crosse Technology, Ltd  
2809 Losey Blvd S.  
La Crosse, WI 54601  
Phone: 608.782.1610  
Fax: 608.796.1020

e-mail:

[support@lacrossetechnology.com](mailto:support@lacrossetechnology.com)  
(warranty work)

[sales@lacrossetechnology.com](mailto:sales@lacrossetechnology.com)  
(information on other products)

web:

[www.lacrossetechnology.com](http://www.lacrossetechnology.com)

## FCC DISCLAIMER

This device complies with part 15 of the FCC rules. Operation is subject to the following two conditions:

- (1) This device may not cause harmful interference.
- (2) This device must accept any interference received, including interference that may cause undesired operation.

La Crosse Technology  
Made in China

All rights reserved. This handbook must not be reproduced in any form, even in excerpts, or duplicated or processed using electronic, mechanical or chemical procedures without written permission of the publisher.

This handbook may contain mistakes and printing errors. The information in this handbook is regularly checked and corrections made in the next issue. We accept no liability for technical mistakes or printing errors, or their consequences.  
All trademarks and patents are acknowledged.