

TX25U
915 MHz
WIRELESS WEATHER STATION

INSTRUCTION MANUAL

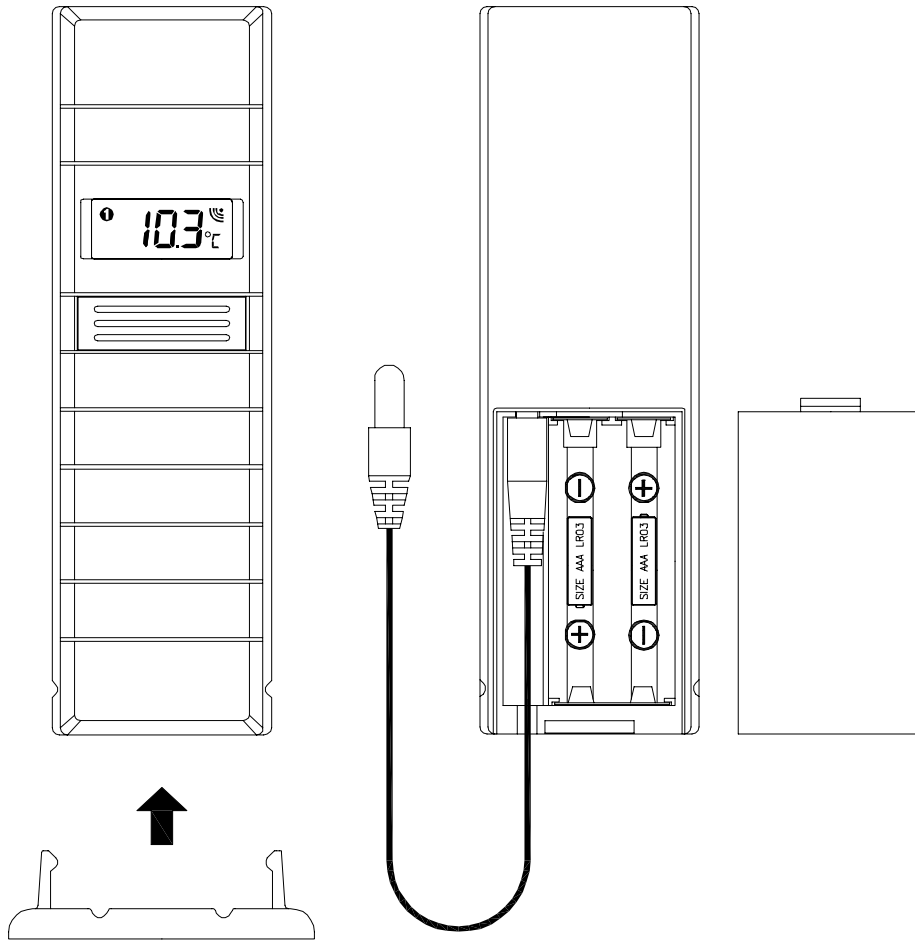

Tomorrow's Weather Today™

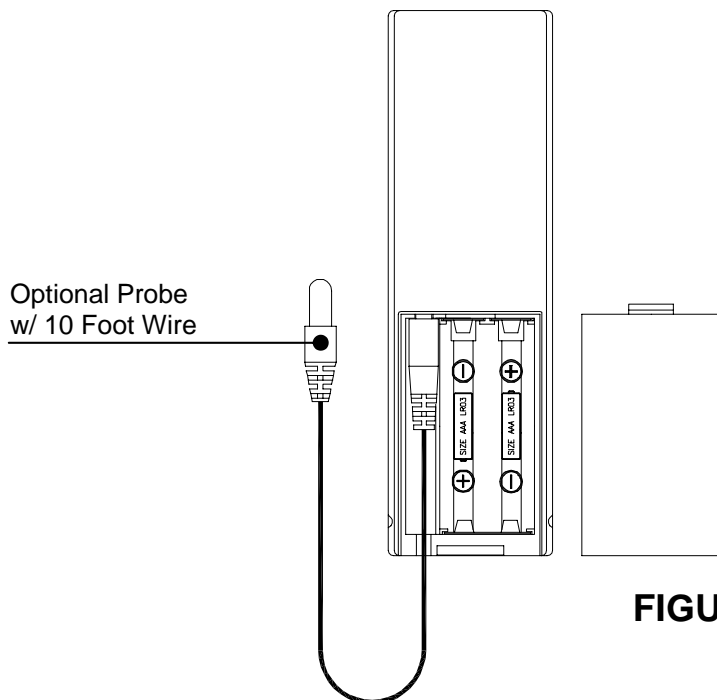

FIGURE 1

ADDITIONAL EQUIPMENT (not included)

1. Two fresh AAA 1.5V alkaline batteries for the **remote temperature sensor**.
3. One, Philips screwdriver for mounting.

QUICK SETUP

Hint: Use good quality Alkaline Batteries; avoid rechargeable batteries.

1. Have the Wireless Weather Station and Temperature sensor 3 to 5 feet apart.
2. Batteries should be out of both units for 10 minutes.
3. Place the batteries into the **Temperature sensor first** and next into the Wireless Weather Station.
4. **DO NOT PRESS ANY BUTTONS FOR 15 MINUTES.**

In this time the Wireless Weather Station and the temperature sensor will begin to communicate with each other, and the display will show both the indoor temperature and an outdoor temperature. If the Wireless Weather Station does not display both temperatures after the 15 minutes, please retry the set up as stated above. After both indoor and outdoor temperatures are displayed for 15 minutes you can place your temperature sensor outdoors, and set your time.

The temperature sensor should be placed in a dry, shaded area (ex: under the eave of a roof). The temperature sensor has a range of 330 feet. Any walls that the signal will have to pass through will reduce distance. An outdoor wall or window will have up to 20 feet of resistance and an interior wall will have up to 10 feet of resistance. Your distance plus resistance should not exceed 330 feet in a straight line.

NOTE: Fog and mist will not harm your temperature sensor, but direct rain must be avoided.

DETAILED SETUP GUIDE

I. BATTERY INSTALLATION (When one Temperature sensor is being used)

1. First, insert the batteries to the Temperature sensor (see “**A. Temperature sensor**” below).
2. Within 2 minutes of powering up the sensor, insert the batteries to the Weather Station (see “**B. Wireless Weather station**” below). Once the batteries are in place, all segments of the LCD will light up briefly. Following the indoor temperature and the time as 12:00 will be displayed, and the signal reception icon will flash. If they are not shown in LCD after 60 seconds, remove the batteries and wait for at least 60 seconds before reinserting them. Once the indoor data is displayed user may proceed to the next step.
3. After the batteries are inserted, the Weather Station will start receiving data signal from the sensor. The outdoor temperature should then be displayed on the Weather Station. If this does not happen after 2 minutes, the batteries will need to be removed from both units and reset from step 1.

A. TEMPERATURE SENSOR

1. Remove the **Battery Cover**.
2. Observing the correct polarity, install 2 “**AAA**” **Alkaline Batteries**—make sure they do not spring free, or start-up problems may occur.
3. Replace the **Battery Cover**.

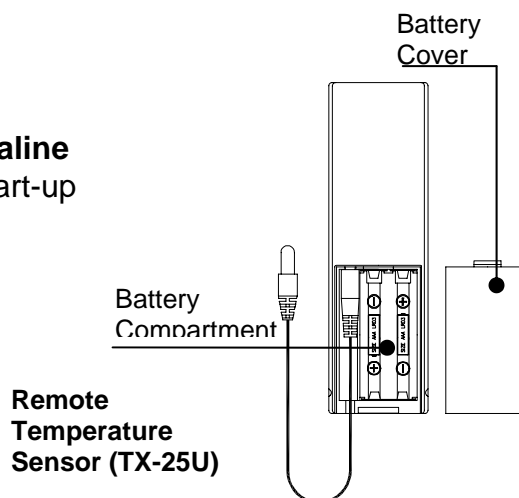

OUTDOOR TEMPERATURE

The temperature received from the remote temperature sensor is viewed in the OUTDOOR LCD. When there is more than one remote temperature sensor unit in operation, a “boxed” number will appear to the right of the temperature. This indicates which remote temperature sensor unit (1, 2, or 3) is currently displaying its data in the OUTDOOR LCD. (This feature is explained in further detail in the section—*Adding Remote Temperature Sensors*).

OPTIONAL CHANNEL 2 TEMPERATURE PROBE

When the temperature probe is connected to the remote temperature sensor, the WS-9029U's channel 1 will display the remote temperature sensor data, and channel 2 will display the temperature probe data. The remote temperature sensor data will always be displayed on the channel 1 and the temperature probe on the channel 2.

If the probe on remote temperature sensor is unplugged, the "probe channel" on WS-9029U LCD will show "---", the remote temperature sensor displayed value will still be shown.

The probe can be connected to the remote temperature sensor anytime. There is no need to reset the units. The Weather Station will automatically detect the temperature probe and will display the temperature probe data in channel 2.

ADDING TEMPERATURE SENSORS (OPTIONAL)

The WS-9029U is able to receive signals from 2 remote temperature sensors (TX-25U). These extra sensors can be purchased through the same dealer as this unit

A. SET-UP OF MULTIPLE SENSORS

1. Remove all the batteries from the receiver and sensor(s) and wait 60 seconds. During these 60 seconds, press any button 20 times to discharge any excess power.
2. Insert the batteries to the first sensor.
3. Within 2 minutes of powering up the first sensor (Temperature sensor with probe), insert the batteries to the Weather Station. Once the batteries are in place, all segments of the LCD will light up briefly. Following the indoor temperature/humidity and the time as 12:00 will be displayed, and the signal reception icon will flash. If they are not shown in LCD after 60 seconds, remove the batteries and wait for at least 60 seconds before reinserting them.
4. The outdoor temperature from the first sensor (channel 1) should then be displayed on the Weather station. If this does not happen after 2 minutes, the batteries will need to be removed from both units and reset from step 1.
5. If the temperature probe has been used, the outdoor temperature from channel 2 will then be displayed. Otherwise, the outdoor temperature will display "---".

Note: The temperature probe from the first sensor will always occupy "channel 2". Channel 2 can only be used for the temperature probe. If you choose not to use the temperature probe, Channel 2 will display "---".

6. Insert the batteries to the second sensor as soon as the outdoor temperature readings from the first sensor are displayed on the Weather station.

NOTE: You must insert the batteries into the second sensor within 30 seconds of reception of the first sensor.

7. The outdoor temperature from the second sensor and the "channel 3" icon should then be displayed on the Weather station. If this does not happen after 2 minute, the batteries will need to be removed from all the units and reset from step 1.

Note: only the readings from the internal sensor of the second sensor will be displayed in "channel 3"

IMPORTANT: Transmission problems will arise if the setting for additional sensors is not followed as described above. Should transmission problems occur, it is necessary to remove the batteries from all units and start again the set-up from step 1.

B. VIEWING AND OPERATING WITH MULTIPLE TEMPERATURE SENSOR UNITS

1. To view the temperature of a different remote temperature sensor unit, press and release the *SET/CH* button. A shift from one "boxed" number to the next should be observed in the OUTDOOR LCD.
2. To determine which remote temperature sensor reading is displayed on the 3 channels, match the temperature displayed on each channel, with the corresponding temperature displayed on the LCD of each remote temperature sensor.
3. To view the Minimum/Maximum temperature: first select which remote temperature sensor to read data from (indicated by the "boxed" number), then press the *SET/CH* button. Pressing this button once will display the minimum temperature, and the date and time the data was recorded. Pressing this button a second time (while "MIN" is still displayed, otherwise press the button twice) will display the same data for the maximum recordings.
4. To reset the Minimum/Maximum readings, press and hold the *MIN/MAX/+* button for 5 seconds, this will reset all the minimum and maximum data from all sensors.

MOUNTING

THE REMOTE TEMPERATURE SENSOR

1. Remove the mounting bracket/stand from the temperature sensor.
2. Place the mounting bracket over the desired location.
3. The mounting bracket can attach to the sensor in the middle of the back or on the bottom.

4. Through the 3 screw holes of the bracket, mark the mounting surface with a pencil.
5. Screw mounting bracket onto the mounting surface. Ensure that the screws are flush with the bracket.
6. Insert the remote temperature sensor into the bracket.

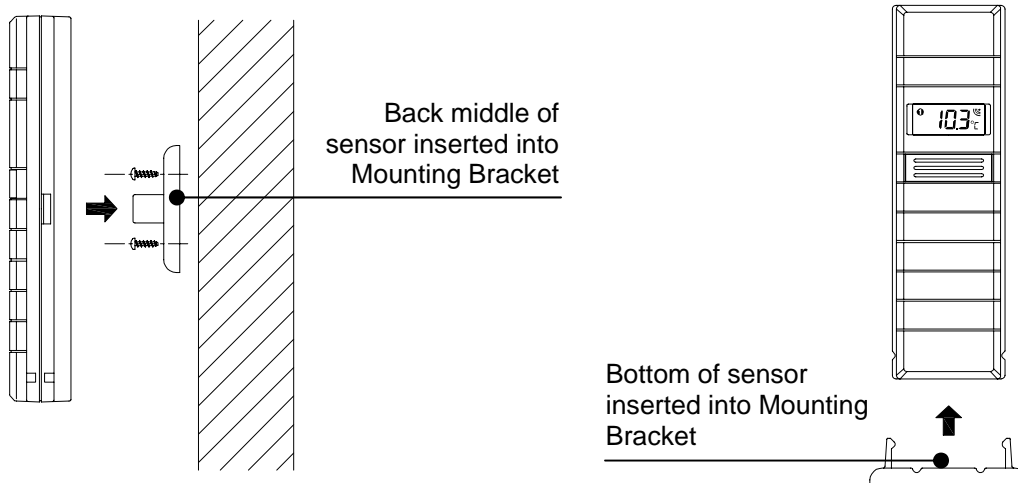

Problem: No outdoor temperature is displayed.

- Solution:**
- 1) Remove all batteries, reinsert into sensor first, then into the wireless weather station.
 - 2) Place remote temperature sensor closer to wireless weather station.
 - 3) Be sure all batteries are fresh.
 - 4) Place remote temperature sensor and wireless weather station in position so the straight-line signal is not passing through more than 2 or 3 walls.

Problem: Temperatures do not match if units are placed next to each other.

Solution: Each remote temperature sensor is manufactured to be accurate to within 1 degree plus or minus and under normal conditions, so two sensors could be as much as 2 degrees different. However, the difference can be exaggerated further because the sensors are designed for different working environments. The indoor sensor is less responsive to ambient air currents because of the shielding effect of the display's case. In addition, the case can act as a heat sink to absorb and store heat from external sources (i.e. handling of the case or radiant heat). Also, the much greater range of the remote temperature sensor requires a different calibration curve than the indoor range. Error is usually greater at the extreme ends of a range, making it harder to compare different ranges with different curves. Under non-laboratory conditions, it is difficult to compensate for the above factors and obtain an accurate comparison.

MAINTENANCE AND CARE INSTRUCTIONS

- ✓ Extreme temperatures, vibration, and shock should be avoided to prevent damage to the units.
- ✓ Clean displays and units with a soft, damp cloth. Do not use solvents or scouring agents; they may mark the displays and casings.
- ✓ Do not submerge in water.
- ✓ Immediately remove all low powered batteries to avoid leakage and damage.
- ✓ Opening the casings invalidates the warranty. Do not try to repair the unit. Contact La Crosse Technology for repairs.

WARRANTY INFORMATION

La Crosse Technology, Ltd provides a 1-year limited warranty on this product against manufacturing defects in materials and workmanship.

This limited warranty begins on the original date of purchase, is valid only on products purchased and used in North America and only to the original purchaser of this product. To receive warranty service, the purchaser must contact La Crosse Technology, Ltd for problem determination and service procedures. Warranty service can only be performed by a La Crosse Technology, Ltd authorized service center. The original dated bill of sale must be presented upon request as proof of purchase to La Crosse Technology, Ltd or La Crosse Technology, Ltd's authorized service center.

La Crosse Technology, Ltd will repair or replace this product, at our option and at no charge as stipulated herein, with new or reconditioned parts or products if found to be defective during the limited warranty period specified above. All replaced parts and products become the property of La Crosse Technology, Ltd and must be returned to La Crosse Technology, Ltd. Replacement parts and products assume the remaining original warranty, or ninety (90) days, whichever is longer. La Crosse Technology, Ltd will pay all expenses for labor and materials for all repairs covered by this warranty. If necessary repairs are not covered by this warranty, or if a product is examined which is not in need of repair, you will be charged for the repairs or examination. The owner must pay any shipping charges incurred in getting your La Crosse Technology, Ltd product to a La Crosse Technology, Ltd authorized service center. La Crosse Technology, Ltd will pay ground return shipping charges to the owner of the product to a USA address only.

Your La Crosse Technology, Ltd warranty covers all defects in material and workmanship with the following specified exceptions: (1) damage caused by accident, unreasonable use or neglect (including the lack of reasonable and necessary maintenance); (2) damage occurring during shipment (claims must be presented to the carrier); (3) damage to, or deterioration of, any accessory or decorative surface; (4) damage resulting from failure to follow instructions contained in your owner's manual; (5) damage resulting from the performance of repairs or alterations by someone other than an authorized La Crosse Technology, Ltd authorized service center; (6) units used for other than home use (7) applications and uses that this product was not intended or (8) the products inability to receive a signal due to any source of interference.. This warranty covers only actual defects within the product itself, and does not cover the cost of installation or removal from a fixed installation, normal set-up or adjustments, claims based on misrepresentation by the seller or performance variations resulting from installation-related circumstances.

LA CROSSE TECHNOLOGY, LTD WILL NOT ASSUME LIABILITY FOR INCIDENTAL, CONSEQUENTIAL, PUNITIVE, OR OTHER SIMILAR DAMAGES ASSOCIATED WITH THE OPERATION OR MALFUNCTION OF THIS PRODUCT. THIS PRODUCT IS NOT TO BE USED FOR MEDICAL PURPOSES OR FOR PUBLIC INFORMATION. THIS PRODUCT IS NOT A TOY. KEEP OUT OF CHILDREN'S REACH.

This warranty gives you specific legal rights. You may also have other rights specific to your State. Some States do not allow the exclusion of consequential or incidental damages therefore the above exclusion of limitation may not apply to you.

For warranty work, technical support, or information contact:

La Crosse Technology
2809 Losey Blvd. S.
La Crosse, WI 54601
Phone: 608.782.1610
Fax: 608.796.1020

e-mail:

support@lacrossetechnology.com
(warranty work)

sales@lacrossetechnology.com
(information on other products)

web:

www.lacrossetechnology.com

All rights reserved. This handbook must not be reproduced in any form, even in excerpts, or duplicated or processed using electronic, mechanical or chemical procedures without written permission of the publisher.

This handbook may contain mistakes and printing errors. The information in this handbook is regularly checked and corrections made in the next issue. We accept no liability for technical mistakes or printing errors, or their consequences.

All trademarks and patents are acknowledged.